

dH Wind Tunnel

Basic user guidelines

All new users should be introduced to the facility by a competent person who is familiar with its operation. All safety and operational guidelines must be adhered to. These notes are not a substitute for a code of practice, safety guidelines or any technical manual.

If you are in doubt about anything, ask someone who knows about and understands the facility.

About the wind tunnel

<http://www.gla.ac.uk/schools/engineering/research/divisions/aerospace/researchfacilities/windtunnelfacilities/nationalwindtunnelfacility/>

- Part of UK National Wind Tunnel Facility
- Closed return, 5:1 contraction ratio
- Octagonal working section, 2.66m wide x 2.1m high x 5.4m long
- eDrawing on URL above
- Maximum speed is 70 m/s
- Turbulence level <1%
- Turntable and sting mounted balance system are centre-piece of working section
- Force and moment measurement through:
 - Sting system
 - Platform mounted load cell on turntable
 - Other load cells
- Large area and high speed stereo PIV systems (LaVision)
- Three component LDA (Dantec) with 1m x 1m x 1m traverse volume
- Three component CTA (Dantec)
- PSP system
- 64 channel ZOC pressure scanner
- Five hole probe, pressure rakes
- High speed cameras, strobes and lighting
- Data acquisition capability with amplification and signal conditioning
- Hydraulic and electric actuation systems
- Traverses

Wind tunnel control room

- Tests tend to be operated from the control room
- Be familiar with how the control room is set up before you attempt to do anything with the tunnel
- Do not interfere with the set up of any of the computers in the control room. The systems operate through a local network that provides all the functionality required and is easily interfaced with.
- Report any user issues.

General usage guidelines

- The wind tunnel is a scientific instrument
- Look after the tunnel, it does not look after itself
- You are responsible for the safe operation of the wind tunnel and its instrumentation
- Be familiar with the operation of the instrumentation you are using
 - Understand the physical limits
- When you have finished using the tunnel ensure it is in a fit state for the next user

Looking after the wind tunnel

- Supervisors and users take responsibility for the facility
- Keep track of all tools going into the wind tunnel, count them in and count them out, do not leave loose items in the tunnel
- Be pragmatic when setting up, but do not misappropriate things
- Load cells and balances are delicate, do not abuse them
- Class 4 lasers are installed, be familiar with and respect them
- Cleaning the inside of the tunnel is a time-consuming and arduous task; avoid doing anything that makes a mess of the inside of the tunnel (oil based flow visualisation methods make a terrible mess)

Important note on oil substrate methods

- Wet oil for surface flow visualisation passes around the whole circuit
- Oil from the smoke wand is dense

- The above two oil methods contaminate the gauze rapidly and leave a thick oil deposit around the entire tunnel. The oil deposits on the gauze build up quickly to form a thick sludge which is difficult to remove, the floors become slippery and difficult to walk on

- *A clean gauze is critical to the correct performance of the tunnel*

- Do your best to avoid using the above techniques – use sparingly if at all
- Alternatives: liquid crystals, tufts

Oil substrate for PIV/ LDA

- Historically has not been observed to affect the tunnel adversely
- There is a slow build up on the gauze
- Clean the gauze using the foam mop on the long pole after your PIV/ LDA campaign

- Avoid oil substrate, use DEHS in the seeder

Cleaning the wind tunnel

- Downstream side of gauze, settling chamber, contraction and first diffuser leg all accessible from working section
- Access to upstream side of gauze through access hatch. This is hazardous! Inform supervisor, school technicians, and only do this with technician supervision and with the tunnel locked off

- Sweep or vacuum dust
- Mop floors for oil
 - Use strong concentration of floor cleaning detergent
 - Floor gets slippery, take care
 - Dry with paper towels, cardboard

- Use foam mop on long pole for cleaning the gauze, both sides need to be cleaned. Stubborn deposits need to be cleaned with steam cleaner, scaffolding needs to be erected to reach high areas.

Safe operation of the tunnel

- Planning and preparation are essential
- Your model must not break apart during its test; your design must be approved by your supervisor
- Model must be mounted securely using screws and bolts
 - Do not rely on interference fits
- Observe laser safety guidelines
- Monitor the wind tunnel dynamic pressure/ speed during your test
- Monitor the wind tunnel motor state during your test
 - Reduce speed if lxt alarm shown on motor monitor PC
 - Report all tunnel shutdown incidents
- Work is mentally and physically demanding
 - Take a break or stop for the day if you're tired

Routine maintenance of the tunnel

- Clean and tidy up after test campaign
- Bearings need greasing (once per month at least, technician help)
- Check laser and chiller coolant levels prior to use and daily when in use
- Check laser mirrors are covered when not in use
- Keep working section windows clean during PIV/ LDA/ visualisation tests
- Keep instrumentation in good order and where it should be
- Keep tool kit in order, ensure nothing is missing
- Perform internal and external inspection
- Keep control room, platform, plant room and on top of tunnel tidy
- Report any uncommanded tunnel shutdown incidents

Tunnel operation

- This includes operating the tunnel and its instrumentation
- Plan and prepare, ensure you are trained beforehand
- Know and understand your instrumentation
- Tunnel speed displayed on computer, speed set (currently) using hand set.
- Set tunnel speed using the dial
- Do NOT press the emergency stop mushroom button if the tunnel is on
- Do not press the green button to operate the tunnel without checking the dial first
- Tunnel speed from Pitot probe in working section, check it is not fouled or leaking

Control room operation: network

- 48 channel ethernet switch in turn connected to a wireless ethernet switch
- All PCs except for the motor state monitoring PC are connected to the network
- Local network does not connect to university network, NEVER attempt to connect it to the university network
- Take care connecting a new PC to the network
 - Ensure no IP address clashes
 - Ensure correct ethernet connection socket on PC is being used
- Take care connecting a new device to the network
 - Ensure no IP address clashes
- IP addresses have format 192.168.xxx.yyy

Network layout

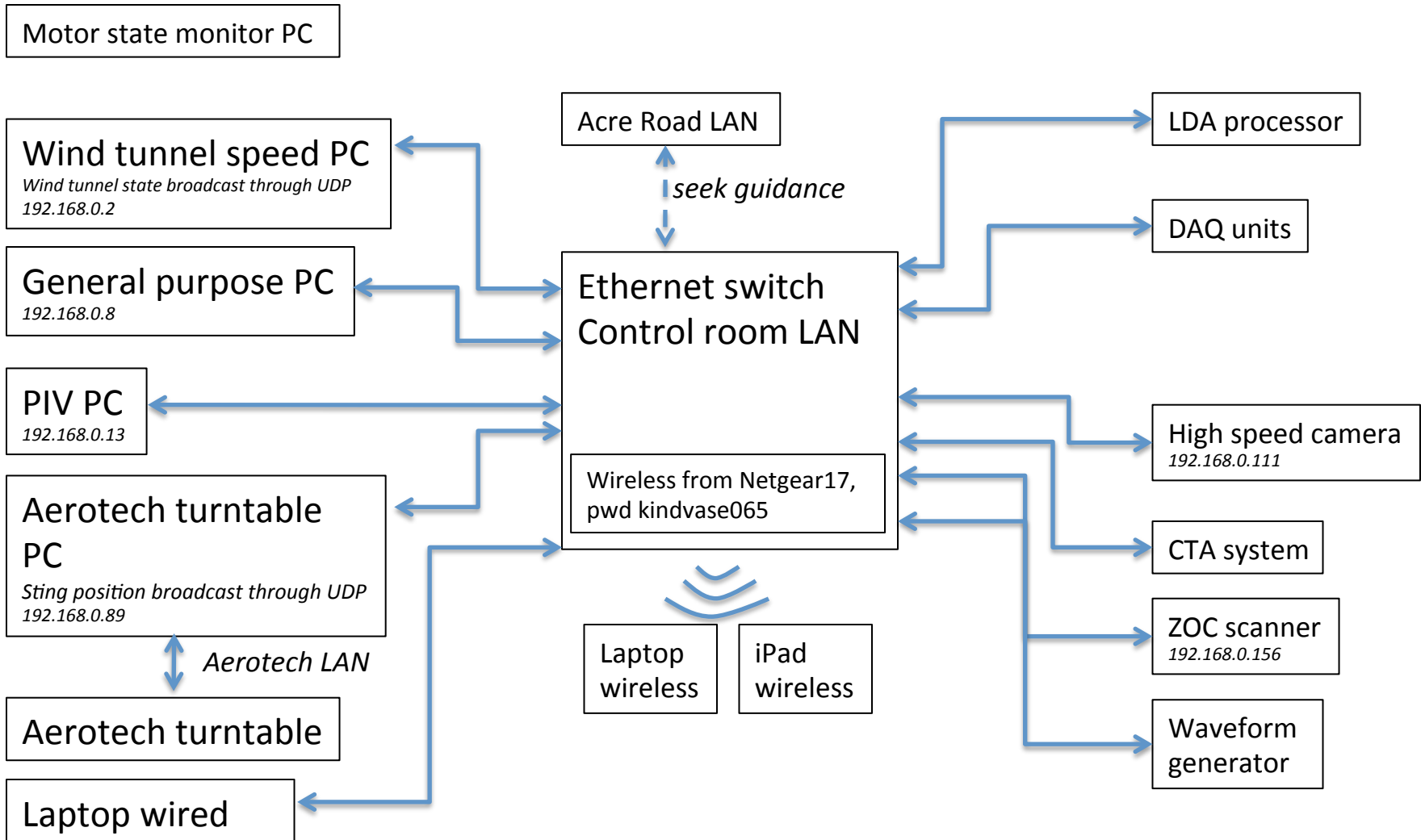

- PCs with exception of Aerotech turntable PC are in control room
- Some systems use USB and serial port connections also
- Data from PC can be accessed through network dependent upon how PC is set up; see IT support
- Remote desktop connection possible through wireless. This is a very useful function for LDA, camera operation, etc

Wind tunnel speed PC

- Shows wind tunnel speed
- Also runs load cells
- Data interface is NI USB device with BNC connectors
- Set of labview programs, use whichever is appropriate
 - Some versions broadcast speed, temperature, barometric pressure, dynamic pressure over UDP
 - Turntable system relies on wind tunnel speed broadcast, ensure correct code is running

Aerotech turntable PC and LAN

- PC is physically located in turntable control cabinet beneath working section
- Turntable run through OGI interface on desktop
 - Yaw, pitch, roll angle broadcast on UDP
 - Reads wind tunnel data off UDP, make sure correct labview code on wind tunnel PC is running before turntable is switched on
- Test data on this PC may be accessed through network if files are made public
- Aerotech LAN is exclusively for turntable system, do not interfere with it

PIV PC (NWTF, 200Hz)

- Use with high speed PIV system
- Runs LaVision Davis 8
- Uses 100mJ, 200Hz lasers on platform
- All PIV system cables to be left connected to the PC
- Connect cameras directly to the PC, not through the switch

PIV PC (legacy large area)

- Large area, low frame rate
- Runs LaVision Davis 7
- Uses 0.5J Litron laser in plant room
- All PIV system cables to be left connected to the PC
- Connect cameras directly to the PC

General purpose PC

- Use with range of systems
- LDA, CTA, high speed camera, data acquisition, ZOC.....
- LDA, CTA, ZOC, high speed camera software on this PC
- Labview, matlab, office suite installed also
- PC is for general use, install additional software on it as required
- This PC is also connected to university network

Motor monitor PC

- PC is connected to Mentor II drive control system in motor room
- Shows drive status
- Legacy PC runs Windows XP
- Not networked

Laptop connection (wired or wireless)

- Ensure no IP address clashes
- Connect laptop to ethernet switch

Laptop and iPad connection (wireless)

- Password for wireless is on interface box
- Allows remote desktop and direct operation of some devices
- Allows PC or iPad to be used in more convenient location

Connection to Acre Road LAN

- This is possible!
- Allows connection to any other device on Acre Road LAN
 - This is not the external GU network
- Ensure there will be no IP address clashes
- Find wall socket that is not connected to GU network
- Connect ethernet switch to wall socket

Computer IP addresses.....

- Fixed addresses only
- See list on noticeboard by kitchen

Device IP addresses.....

- Only an issue if new devices are acquired
- Seek advice

Adding new devices or PCs...

- Ensure no IP address clashes
- Plug equipment into ethernet switch
- Advise whether equipment will be temporary or permanent
- Edit IP address list